

SUMMER 2008



CONTRACTORRR BOX SCRAPERRR  
*Operator's Manual*

**MODERN**  
AG PRODUCTS, LTD.

YOU'RE ALWAYS AHEAD...WITH A MODERN BEHIND.

P.O. BOX 790 • BEAUMONT, TX 77704  
409.833.2665 • 1.800.231.8198 FAX: 409.726.8333  
[www.modernusa.com](http://www.modernusa.com)

*Go Galvanized!*

# CHECK LIST

## **PRE-DELIVERY CHECKLIST**

Inspect the blade thoroughly after assembly to be certain it is set up properly before delivering it to the customer. The following checklist is a reminder of points to inspect. Check off each item as it is found satisfactory or after proper adjustment is made.

## **DELIVERY CHECKLIST**

\_\_\_ Remove and reposition center scarifier shank that is bolted in an upside down shipping position.

\_\_\_ Show customer how to make adjustments.

\_\_\_ Point out safety features.

\_\_\_ Give Operator's Manual to the customer and ask him to familiarize himself with all sections of it.

## **DAILY CHECKLIST**

\_\_\_ Check that unit is properly and securely attached to tractor.

\_\_\_ During inspection, check that all hardware is secure and cotter pins are in place.

\_\_\_ Check that cutting edge of blade is in good condition.

I have thoroughly instructed the buyer on the above described equipment, the review included the Operator's Manual content, equipment care, adjustments and safety information.

\_\_\_\_\_  
Date \_\_\_\_\_ Dealer's Rep Signature \_\_\_\_\_

The above equipment and Operator's Manual have been received by me and I have been thoroughly instructed as to care, adjustments and safe operations.

\_\_\_\_\_  
Date \_\_\_\_\_ Owner's Signature \_\_\_\_\_

# SAFETY SECTION

The **SAFETY ALERT SYMBOL**  indicates that there is a potential hazard to personal safety involved and extra safety precautions must be taken. When you see this symbol on your machine or in this manual, be alert and carefully read the message that follows it.

**DANGER:** Indicates an imminently hazardous situation which, if not avoided, will result in death or serious injury. This signal word is limited to the most extreme situations.

**WARNING:** Indicates a potentially hazardous situation which, if not avoided, could result in death or serious injury.

**CAUTION:** Indicates a potentially hazardous situation which, if not avoided, may result in minor or moderate injury. It may also be used to alert against unsafe practices.

## OPERATION

### **WARNING**

Know your controls and how to stop tractor and engine quickly in an emergency. **READ THIS MANUAL AND THE ONE PROVIDED WITH YOUR TRACTOR.**

To avoid accident or injury, do not allow anyone to operate this equipment without proper instructions. Any person who operates this equipment must be instructed in and be capable of the safe operation of the unit, its attachments and all controls.

Always wear relatively tight and belted clothing to avoid entanglement in moving parts. Wear sturdy, rough soled work shoes. Never operate tractor or implements in bare feet, sandals or sneakers.

### **WARNING**

Do not let anyone operate the machine and scraper without proper instruction.

Operate scraper only from operator's seat. Avoid excessive rate of drop.

Keep children and others away when you operate machine.

Always lower the blade to the ground and stop engine before getting off the tractor.

Look carefully behind tractor for children before you back up.

### **CAUTION**

DO NOT allow children to operate tractor.

### **DANGER**

Do not tow anything with scraper.

Do not allow riders on blade at any time. Do not stand or ride in or on scraper.

## SAFETY SECTION CONTINUED

### **WARNING**

Do not use scraper as a battering ram.

Remove obstacles from scraper path.  
Travel slowly over rough ground.

When you drive with scraper on a road or highway, use accessory lights and safety alert devices.

Before you leave tractor, lower scraper to ground.

Inspect scraper carefully.

### **CAUTION**

Unauthorized modifications to the tractor or scraper may impair the function and/or safety and affect machine and scraper life.

Before you drive tractor, raise scraper to full height.

Avoid working near the edge of deep ditches or trenches.

## MAINTENANCE

### **DANGER**

Never work without safety blocks.

### **WARNING**

Lower scraper to lowest possible position before working on scraper.

Keep hands, feet and clothing away from cutting edges and scarifier shanks.

Keep tractor and scraper in good operating condition and all safety devices in place.

Periodically tighten all bolts and nuts and check that all cotter pins are properly installed to ensure scraper is in a safe condition.

# **OPERATION & PARTS SECTION**

# OPERATION

This unit is designed for a wide range of applications: it may be used for smoothing, grading, scraping, leveling, clearing and landscaping to name a few.

The safe operation of this unit is the responsibility of the operator, who must be properly trained and qualified. Operators should be familiar with the scarifier shanks, cutting edge and all safety practices before starting operation.

## **TRACTOR SIZE**

The scraper may be mounted on any wheeled tractor of maximum 50 HP.

## **RAISING AND LOWERING SCRAPER**

Push tractor level forward to lower scraper. Pull level to rear to raise scraper.

Lower scraper to desired operating position. Lift depth stop lever, and move it against control lever. Push depth stop lever down to lock it.

The scraper will then return to same depth each time it is lowered.

## **LEVELING AND SCRAPING**

To level, make shallow cuts. Move loose dirt into low areas.

When scraping or excavating, determine depth of cut by ground conditions and length of cut needed to fill the box.

## **ADJUSTING SCARIFIER SHANKS**

**CAUTION: Before you adjust shanks, stop engine, block up scraper.**

Scarifier teeth can be set in three positions:

Upper: Shanks will not penetrate soil.

Center: Shanks penetrate bumps.

Lower: Shanks penetrate soil.

Remove bolts and nuts to raise or lower shanks to desired setting. Insert bolt and nut and tighten.

Figure 2

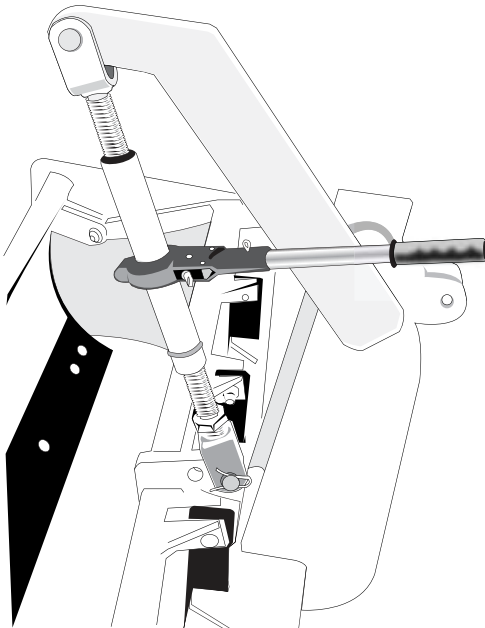

**FIGURE 1**

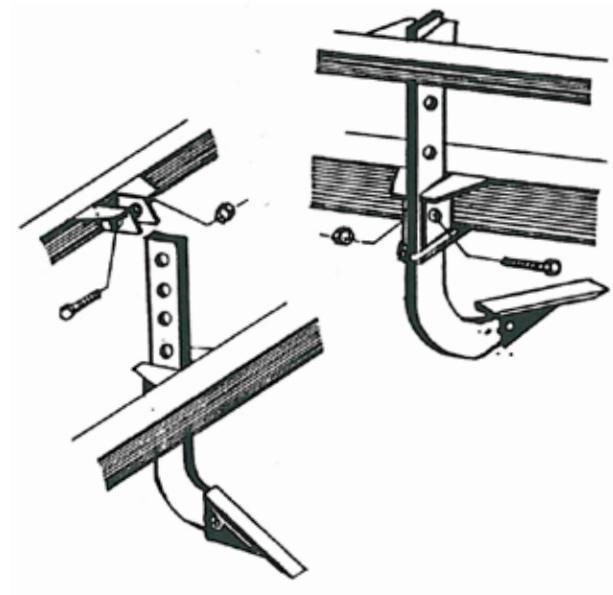

**FIGURE 2**

# OPERATION

## **BACKFILLING**

Adjust scarifier teeth to upper position. Level scraper front-to-rear by adjusting tractor center link. Push dirt with rear cutting edge.

## **TRACTOR ADJUSTMENTS**

See your tractor operator's manual for the following:

Drawbar: Put drawbar in short position.

Leveling: Level cutting edge side-to-side using tractor life link. Level front-to-rear by turning tractor center link.

Rate to Drop: Adjust rate-to-drop so it is enough to be safe.

Sway control: Adjust anti-sway chins on 3-point hitch to prevent scraper from swaying.

Float: Adjust draft links for lateral float to allow scraper to float over objects or uneven ground.

## **REVERSING OR REPLACING CUTTING EDGE**

**CAUTION: Before you work on cutting edge:**

- Put blocks (or stands) under frame.
- Lower scraper onto blocks.
- Replace damaged or missing hardware.

Remove bolts from cutting edge.  
Reverse or replace cutting edge.

Fasten cutting edge with bolts.

## **STORING THE SCRAPER**

If possible, store scraper in a dry place on a hard surface.

Protect scraper from ground moisture (blocks).

Clean box and frame.

Replace worn or damaged parts.

Tighten loose hardware.

Apply touch-up paint to prevent rust.

Put a protective cover over scraper if you store it.

# HYDRAULIC SHANK PARTS LIST

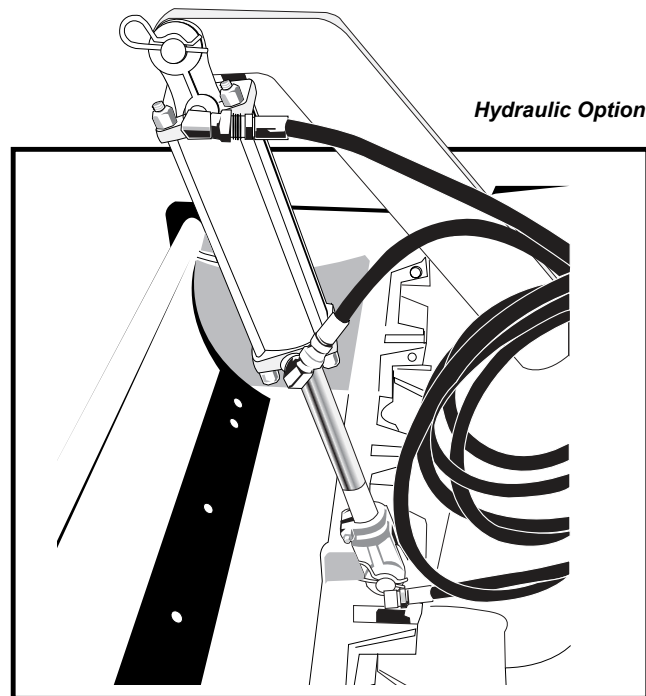
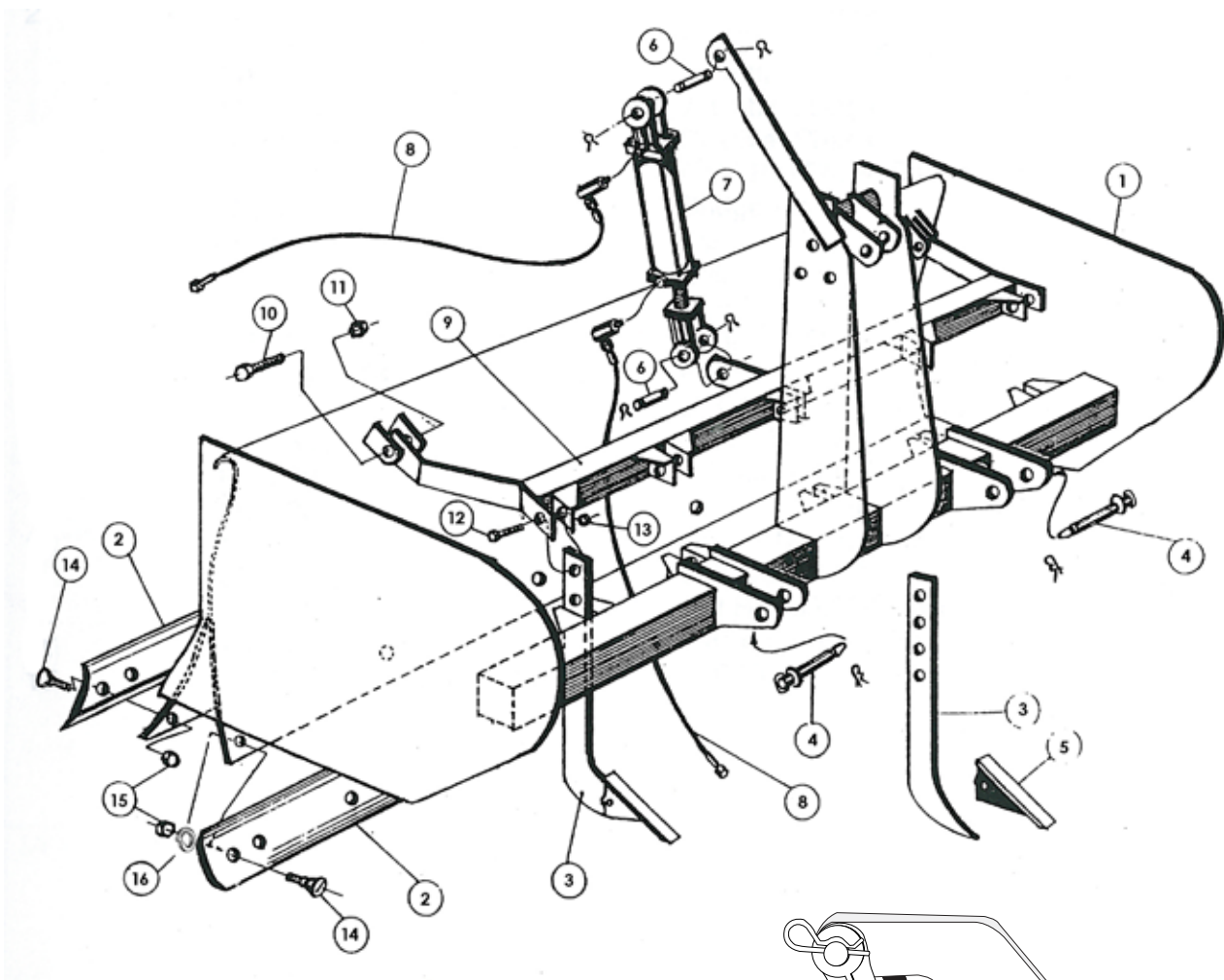

# HYDRAULIC SHANK PARTS LIST

ITEM	PART NO.	QUANTITY	DESCRIPTION
1	102-3561	1	.6' Hyd Lift Box Blade
	102-6570	1	.7' Hyd Lift Box Blade
2	416-8430	2	.6' Cutting Edge
	416-3906	2	.7' Cutting Edge
3	402-8287H	AR	Scarifier Shank
4	412-6389	2	Cat 1 Pull Pin w/Bridge Pin
5	402-8495	AR	Replaceable Point
6	261-700	2	Cylinder Pin
7	263-2088	1	Hydraulic Cylinder
8	415-0036	2	Hose Assy
9	102-2806	1	.6' Welded Lift Arm
	102-2807	1	.7' Welded Lift Arm
10	412-2803	2	Bolt .5" x 2" HH NC
11	412-3243	2	Nut .5" NC Nylock
12	412-1501	AR	Bolt .5' x 2.5" HH NC Gr 5
13	412-5284	AR	Nut .5" NC Nylock
14	412-4699	AR	.5/8" x 1.75" Plow Bolt
15	412-0059	AR	.5/8" Nut
16	412-0073	AR	.5/8" Lockwasher
Not Shown			
17	263-46900	1	Seal Kit for Hyd Cylinder

# MECHANICAL SHANK PARTS LIST

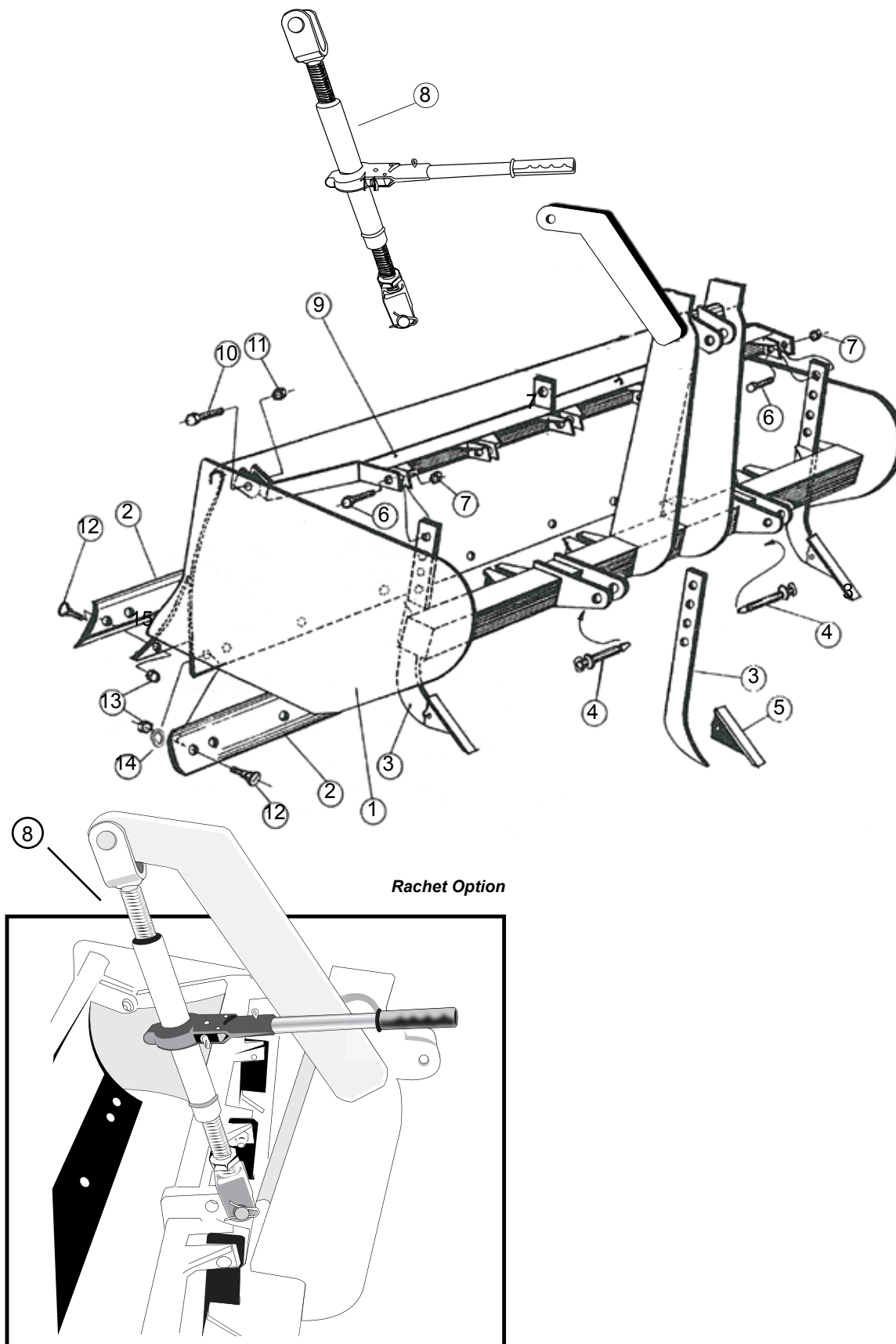

# MECHANICAL SHANK PARTS LIST

ITEM	PART NO.	QUANTITY	DESCRIPTION
1	102-3555	1	5.5' Frame
	102-3561	1	6' Frame
	102-6570	1	7' Frame
2	402-6428	2	5.5' Cutting Edge
	416-8430	2	6' Cutting Edge
	416-3906	2	7' Cutting Edge
3	402-8287H	AR	Scarifier Shank
4	412-6389	2	Cat 1 Pull Pin w/Bridge Pin
5	402-8495	AR	Replaceable Point
6	412-1501	2	Bolt 5/8" x 2.5" HH NC Gr 5
7	412-5284	2	Nut Hex 5/8" NC Nylock
8	159-1542-01	1	Ratchet Jack
9	102-2805	1	5.5' Welded Lift Arm
	102-2806	1	6' Welded Lift Arm
	102-2807	1	7' Welded Lift Arm
10	412-2083	2	Bolt .5' x 2" HH NC
11	412-3243	2	Nut .5" NC Nylock
12	412-4699	AR	5/8" x 1.75" Plow Bolt
13	412-0059	AR	5/8" Nut
14	412-0075	AR	5/8" Lockwasher

# MANUAL SHANK OPERATING SECTION

This unit is designed for a wide range of applications: it may be used for smoothing, grading, scraping, leveling, clearing and landscaping to name a few.

The safe operation of this unit is the responsibility of the operator, who must be properly trained and qualified. Operators should be familiar with the scarifier shanks, cutting edge and all safety practices before starting operation.

## **TRACTOR SIZE**

The scraper may be mounted on any wheeled tractor of maximum 40 HP drawbar rating or tractor weight up to 4000 pounds.

## **RAISING AND LOWERING SCRAPER**

Push tractor level forward to lower scraper. Pull level to rear to raise scraper.

Lower scraper to desired operating position. Lift depth stop lever, and move it against control lever. Push depth stop lever down to lock it.

The scraper will then return to same depth each time it is lowered.

## **LEVELING AND SCRAPING**

To level, make shallow cuts. Move loose dirt into low areas.

When scraping or excavating, determine depth of cut by ground conditions and length of cut needed to fill the box.

## **ADJUSTING SCARIFIER SHANKS**

**CAUTION: Before you adjust shanks, stop engine, block up scraper.**

Scarifier teeth (1) can be set in three positions:

Upper: Shanks will not penetrate soil.

Center: Shanks penetrate bumps.

Lower: Shanks penetrate soil.

Remove bridge pin (3) and scarifier lock (2). Raise or lower shanks to desired setting. Insert bridge pin (3) and Scarifier Lock (2). Figure 1

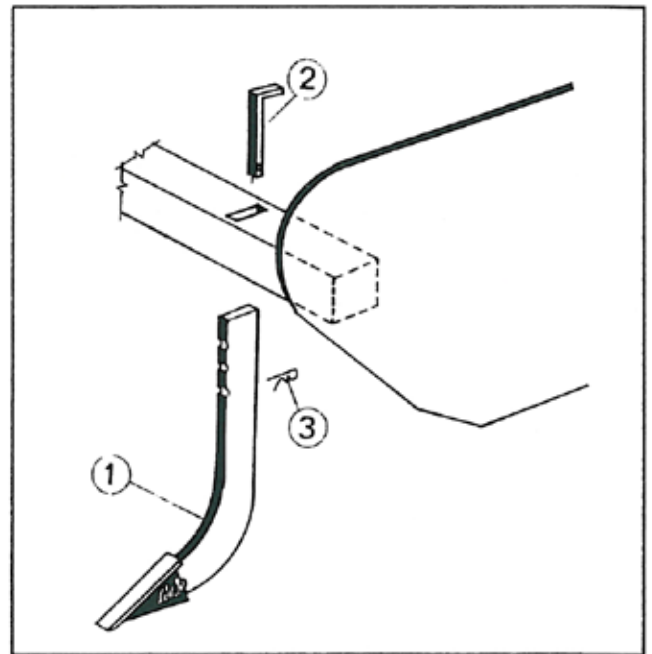

**Figure 1**

## **REPLACING SCARIFIER SHANKS**

**IMPORTANT: Do not operate scarifier with missing or broken shanks.**

Remove scarifier lock (2) and replace used shank with new one (1). Figure 1

# MANUAL SHANK OPERATING SECTION

## **BACKFILLING**

Adjust scarifier teeth to upper position. Level scraper front-to-rear by adjusting tractor center link. Push dirt with rear cutting edge.

## **TRACTOR ADJUSTMENTS**

See your tractor operator's manual for the following:

Drawbar: Put drawbar in short position.

Leveling: Level cutting edge side-to-side using tract lift link. Level front-to-rear by turning tractor center link.

Rate to Drop: Adjust rate-to-drop so it is enough to be safe.

Sway Control: Adjust anti-sway chins on 3-point hitch to prevent scraper from swaying.

Float: Adjust draft links for lateral float to allow scraper to float over objects or uneven ground.

## **REVERSING OR REPLACING CUTTING EDGE**

**CAUTION: Before you work on cutting edge:**

- Put blocks (or stands) under frame.**
- Lower scraper onto blocks.**
- Replace damaged or missing hardware.**

Remove bolts from cutting edge.  
Reverse or replace cutting edge.  
Fasten cutting edge with bolts.

## **STORING THE SCRAPER**

If possible, store scraper in a dry place on a hard surface.

Protect scraper from ground moisture (blocks).

Clean box and frame.

Replace worn or damaged parts.

Tighten loose hardware.

Apply touch-up paint to prevent rust.

Put a protective cover over scraper if you store it.

# MANUAL SHANK PARTS LIST

ITEM	PART NO.	QUANTITY	DESCRIPTION
1 .....	102-3561.....	1.....	6' Frame
.....	102-6570.....	1.....	7' Frame
2 .....	416-8430.....	2.....	6' Cutting Edge
.....	416-3906.....	2.....	7' Cutting Edge
3 .....	402-8287.....	AR.....	Scarifier Shank w/Point
4 .....	402-8495.....	AR.....	Replaceable Point
5 .....	412-6389.....	2.....	Cat 1 Pull Pin w/Bridge Pin
6 .....	900-9006.....	AR.....	Bridge Pin
7 .....	116-6220.....	AR.....	Scarifier Lock
8 .....	412-4699.....	AR.....	5/8"x 1 7/5" Plow Bolt
9 .....	412-0073.....	AR.....	5/8" Lockwasher
10 .....	412-0059.....	AR.....	5/8" Nut

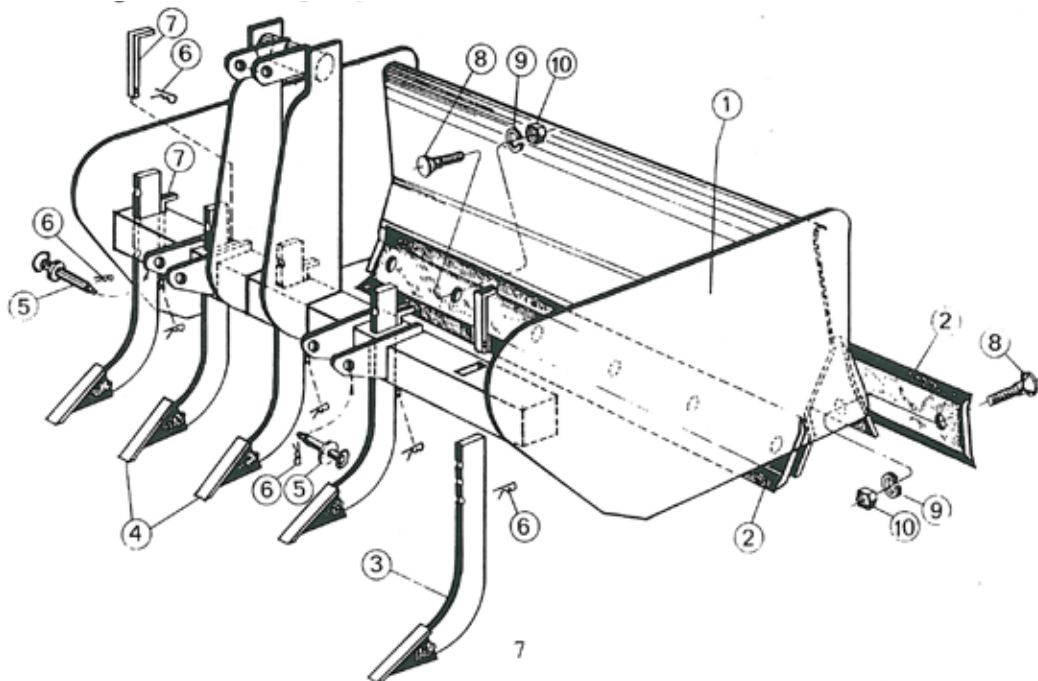

# LIMITED WARRANTY POLICY & REGISTRATION

Modern, Inc. warrants its products for a period of one year after date of sale by authorized dealer to be free from defects in material and workmanship, and will replace at its factory, any parts that will be returned, with shipping charges prepaid, and when examined by us, will disclose it to be defective. This warranty will not apply to implements or parts that have been subjected to misuse, negligence, accident, or that have been altered or repaired.

1. Parts may not be returned without authorization by ModernAg Products.
2. All products returned under warranty inspection claim must be returned PREPAID to our factory.
3. Our obligation under the above warranty is limited to repair or replacement at our factory of any part or parts which Modern, Inc. decides to be defective.
4. Products or parts that have been examined by Modern, Inc. and determined to be improperly operated, damaged by accident or negligence, field repaired or altered, are not covered by this warranty.
5. Modern, Inc. reserves the right to change our specification and designs at any time.
6. This warranty will not obligate Modern, Inc. to bear any cost of labor for field replacement, testing, or adjustment.

---

**DEALER: I hereby certify that:**

1. The machine has been correctly assembled in accordance with manufacturers instructions.
2. All bolts have been checked and tightened.
3. All other pre-delivery checks have been completed as per operators manual.
4. Purchaser was given operators manual and instructed in safe and correct usage of machine and on limitation of warranty.
5. Machine was tested and operates correctly.

**PURCHASER: I hereby certify that:**

1. The machine is correctly assembled.
2. Receipt of the operators manual which I have read and clearly understood.
3. I have a clear understanding of the warranty limitations.
4. I have a clear understanding on the correct and safe operation of the machine
5. That the machine needs regular maintenance as per instructions in operators manual.
6. I have a clear understanding on the capacity of this machine and am aware of its limitations.

MODEL \_\_\_\_\_

SERIAL # \_\_\_\_\_

DEALER \_\_\_\_\_

DATE DELIVERED \_\_\_\_\_

DEALER'S STAMP

MAIL TO:

PURCHASERS ADDRESS: