

# 100 BBL STAINLESS STEEL ISO TANK

ASME VIII Division I 316 Stainless steel "U" stamped tank container. External finish is water based Primer and chlorinated rubber top coat and the internal finish is cold rolled ASTM 2B acid cleaned. Options include: linings, super insulations, handrails, level gauge and electrical heating. RID/ADR, IMO, AAR600, DOT, TC, TIR, UIC, CSC Approved.



## SPECIFICATIONS

- \* Dimensions: 20' long x 8' wide x 8' 6" tall
- \* Capacity: 4,624 GAL.
- \* Barrel/Head Thickness: .315/.335"
- \* Pressures: Working = 100 PSI,  
Test = 150 PSI, Vacuum = 5.9 PSI
- \* Design Temp: 120° C
- \* Tare weight: 9,921 LBS.
- \* Max Payload: 65,036 LBS.
- \* Fittings: Manlid = 500 mm, bolted blank flange with

20 fixings Air Line = 40 mm flanged ball valve with pressure gauge Top Outlet = 3" Fort Vale flanged butterfly valve Safety Relief Valve = 1-2" BSP pressure only with bursting disc fitted Thermometer = Surface type gauge -20°C to +160°C

- \* Steam Heating System: 8 off vee sections producing an effective heating area of 80.7 Sq. FT. at 58 PSI working pressure with a 1" BSP inlet/outlet connections.

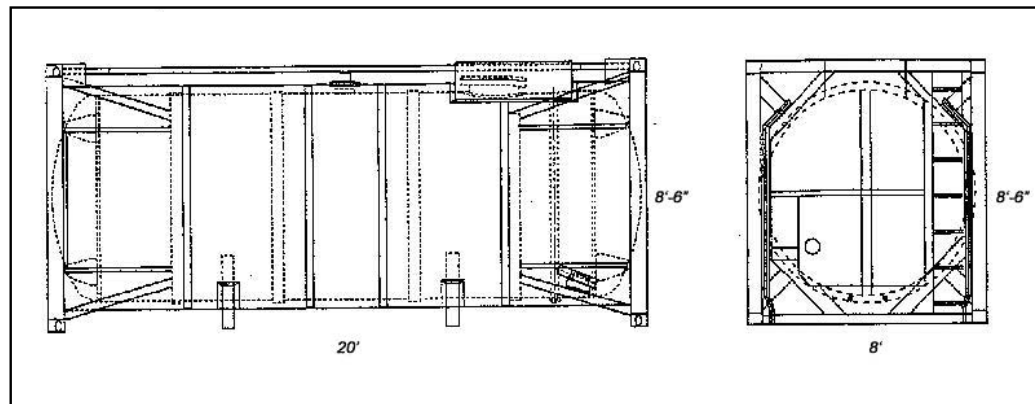

**TIGER OFFSHORE RENTALS** | FLUID TRANSPORT TANKS