

25 BBL MPT (MARINE PORTABLE TANK)

Tank Shell 5/16". Sa-36 plate, GR70, and tank mounting of 3/8 inch steel. 3 inch PRV vent (31 PSI), 20 inch manway, 3 inch Male Camlock with cap. Steel Tubing frame. Stackable. Fork lift pockets on both sides. Tank constructed with 5/16", SA-26 plated cylinder, and 5/16" sa-516, gr 70 PI heads. Pressure and vacuum relief vent flow rate of 4208 cubic feet of free air per minute as required by CFR 49, 178.270-11. Set at 25 PSI/6 in vacuum. The Tiger 25 BBL MPT lift frame is designed for offshore dynamic lifting in accordance with the provisions of API RP 2A and SEPco document OPS0055.

SPECIFICATIONS

- * Exterior coatings, zinc rich epoxy primer, polyurethane top coat
- * Interior coatings, high-build epoxy lining system
- * Tank test pressure 39 PSI
- * Tank maximum working pressure 25psi/6 in. vacuum
- * Tank maximum temperature 200°
- * Max gross weight 25,000 lbs.
- * Tare weight 4,300 lbs.
- * Tank volume 25 bbl 1052 gal.
- * Dimensions: 8' x 5'6", height 7'3"
- * Built in ladder
- * 4 point lifting arrangement

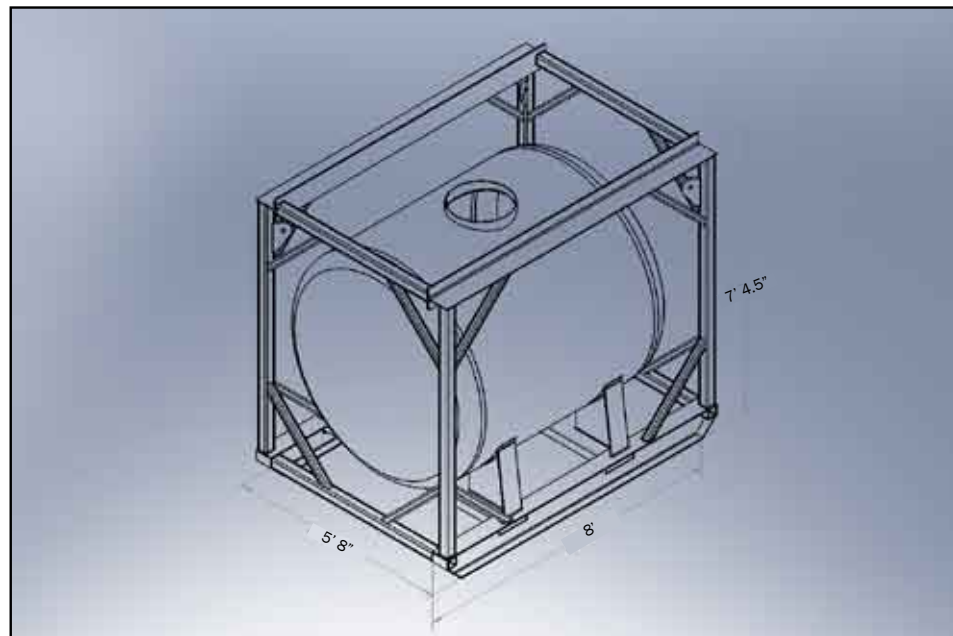

TIGER OFFSHORE RENTALS | FLUID TRANSPORT TANKS