

SUMMER 2008



ROCK & LANDSCAPE RAKE
Operator's Manual

MODERN
AG PRODUCTS, LTD.

YOU'RE ALWAYS AHEAD...WITH A MODERN BEHIND.

P.O. BOX 790 • BEAUMONT, TX 77704
409.833.2665 • 1.800.231.8198 FAX: 409.726.8333
www.modernusa.com

Go Galvanized!

CHECK LIST

PRE-DELIVERY CHECKLIST

Inspect the blade thoroughly after assembly to be certain it is set up properly before delivering it to the customer. The following checklist is a reminder of points to inspect. Check off each item as it is found satisfactory or after proper adjustment is made.

DELIVERY CHECKLIST

- Remove and reposition center scarifier shank that is bolted in an upside down shipping position.
- Show customer how to make adjustments.

Point out safety features.

Give Operator's Manual to the customer and ask him to familiarize himself with all sections of it.

DAILY CHECKLIST

- Check that unit is properly and securely attached to tractor.
- During inspection, check that all hardware is secure and cotter pins are in place.
- Check that cutting edge of blade is in good condition.

I have thoroughly instructed the buyer on the above described equipment, the review included the Operator's Manual content, equipment care, adjustments and safety information.

Date _____ Dealer's Rep Signature _____

The above equipment and Operator's Manual have been received by me and I have been thoroughly instructed as to care, adjustments and safe operations.

Date _____ Owner's Signature _____

SAFETY SECTION

The **SAFETY ALERT SYMBOL**  indicates that there is a potential hazard to personal safety involved and extra safety precautions must be taken. When you see this symbol on your machine or in this manual, be alert and carefully read the message that follows it.

DANGER: Indicates an imminently hazardous situation which, if not avoided, will result in death or serious injury. This signal word is limited to the most extreme situations.

WARNING: Indicates a potentially hazardous situation which, if not avoided, could result in death or serious injury.

CAUTION: Indicates a potentially hazardous situation which, if not avoided, may result in minor or moderate injury. It may also be used to alert against unsafe practices.

OPERATION

WARNING

Know your controls and how to stop tractor and engine quickly in an emergency. **READ THIS MANUAL AND THE ONE PROVIDED WITH YOUR TRACTOR.**

To avoid accident or injury, do not allow anyone to operate this equipment without proper instructions. Any person who operates this equipment must be instructed in and be capable of the safe operation of the unit, its attachments and all controls.

Always wear relatively tight and belted clothing to avoid entanglement in moving parts. Wear sturdy, rough soled work shoes. Never operate tractor or implements in bare feet, sandals or sneakers.

WARNING

Do not let anyone operate the machine and scraper without proper instruction.

Always lower the unit to the ground and stop engine before getting off the tractor.

Always be sure the unit is in the fully raised position when in transport.

Never permit any person other than the operator to ride or board the tractor at any time.

CAUTION

Keep alert and watch ahead as well as behind the tractor when working with the rake.

DANGER

Do not allow rides on frame at any time.

Avoid excessive speed during operation.

SAFETY SECTION continued

WARNING

When turning close to buildings or passing through narrow areas, be sure to allow sufficient clearance for the rake.

Avoid catching the rake on stumps or other immovable objects.

Make adjustments only when the rake is attached to the tractor and lowered to a position to allow safe adjustments.

When making adjustments, be sure that your feet are never under the tines.

Keep all people and pets at a safe distance away when operating the unit.

Always comply with all state and local lighting and marking requirements when operating on highways.

Sand areas where paint is chipped and repaint to prevent rust.

MAINTENANCE SECTION

REPLACING TINES

For replacing tine, remove the 3/8" hex bolt. Remove the tine from frame and reinstall. Replace it when tines are worn or broken.

BOLTS

Keep all the bolts tight at all times by checking them periodically. Replace the bolts only with those having the same marks on the heads as an original bolt.

PREVENT RUST

Sand areas where paint is chipped and repaint to prevent rust.

MAINTENANCE

DANGER

Never work on unit without safety blocks.

CAUTION

Keep engine free of grass, leaves or excess grease to reduce fire hazard.

Travel slowly over rough terrain.

Periodically tighten all hardware to ensure unit is in a safe condition.

Store unit where it cannot fall or tip and injure someone.

OPERATING SECTION

This unit is designed for a wide range of applications: it may be used for landscaping, spreading gravel, raking, windrowing, sand spreading and many other uses.

The safe operation of this unit is the responsibility of the operator, who must be properly trained and qualified. Operators should be familiar with the rake, tractor and all safety practices before starting operation.

TRACTOR SIZE

The rock rake may be mounted on any wheeled Cat 1 tractor.

ROCK RAKE ANGLING

The rake may be angled 180° and can be held at 0°, 15°, 30°, or 45° to left or right for forward grading without unhooking from the tractor. To angle rake, raise it a few inches above the ground by operating the lift control lever of the tractor.

7' ROCK RAKE MAIN ASSEMBLY

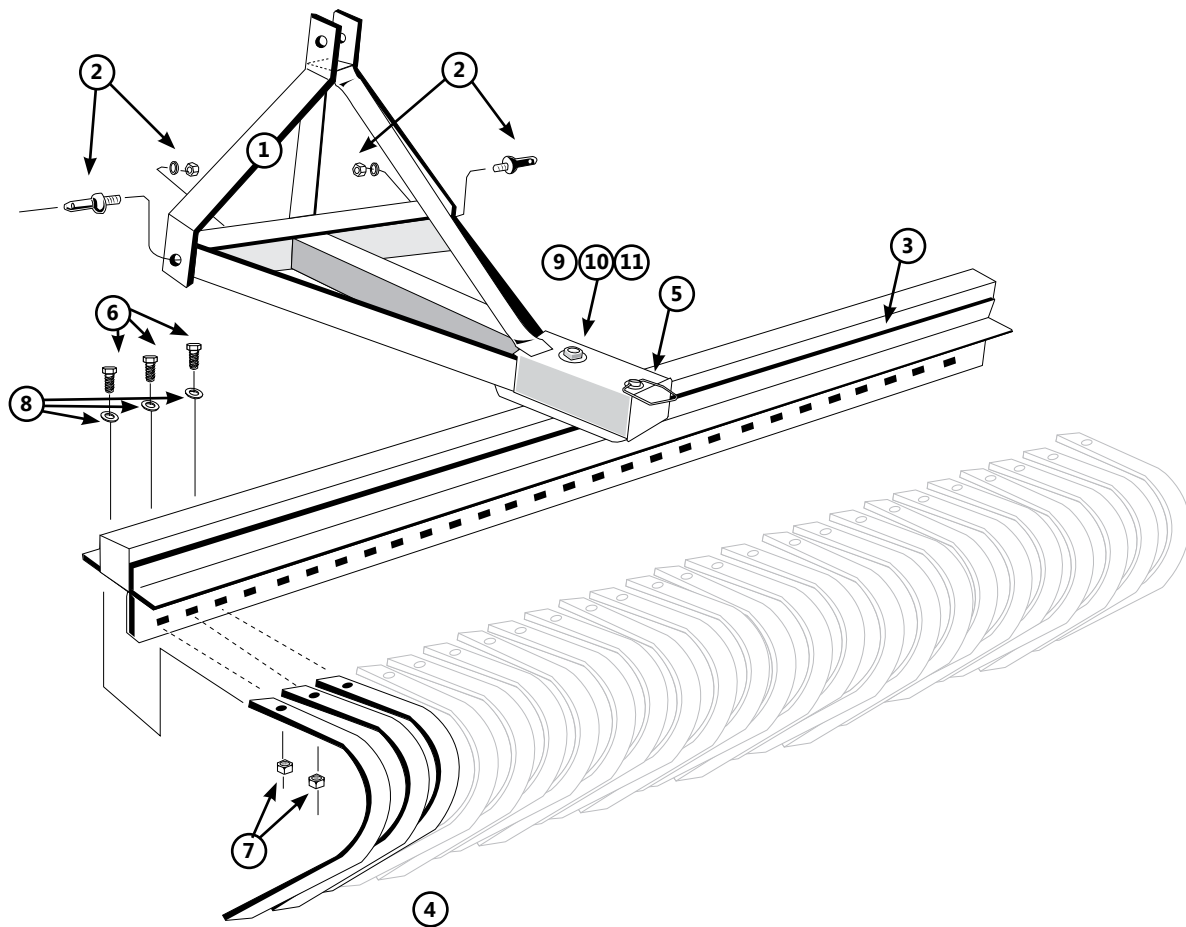

ITEM	PART NO.	QUANTITY	DESCRIPTION
1	103-42771	1	Top Main Frame
2	412-7770	2	Cat I Lift Plan
3	103-33091	1	RR7' Tine Rail Angle
4	406-8601	42	RR7' Tine
5	151-12200	1	Hitch Pin
6	412-2040	42	RR7 3/8" - 16x1-1/2" HHCS
7	412-0657	42	RR7 3/8" Nut
8	412-0071	42	RR7 3/8" Lockwasher
9	412-00471	1	Bolt, 1x5-1/2" GR5
10	412-0068	1	Nylock nut, 1"
11	412-7975	1	Flatwasher, 1"

5' • 6' LANDSCAPE RAKE MAIN ASSEMBLY

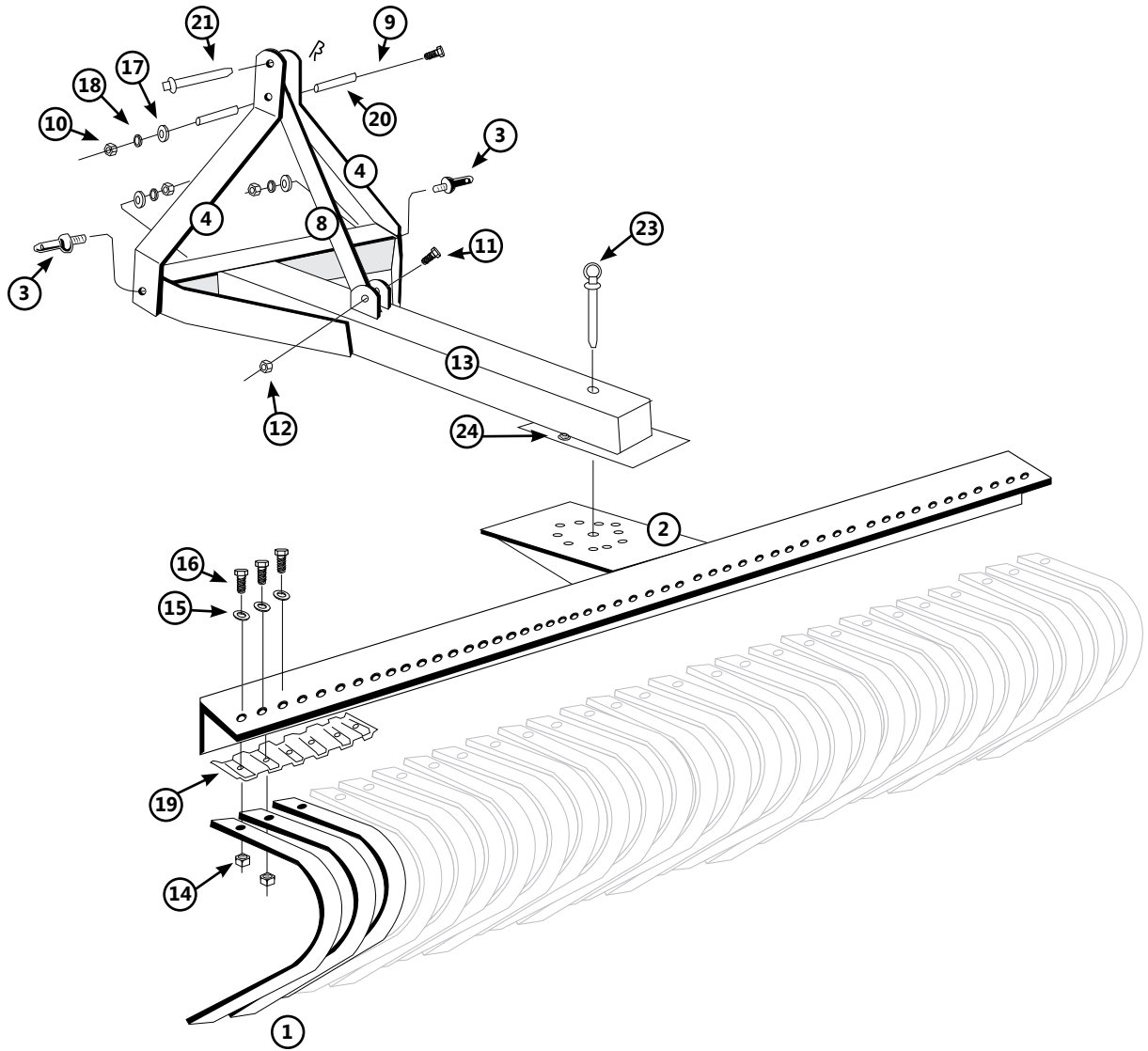

5' • 6' LANDSCAPE RAKE MAIN ASSEMBLY

ITEM	PART NO.	QUANTITY	DESCRIPTION
1	406-8601	30	5' Tine
1	406-8601	36	6' Tine
2	103-33071	1	5' Tine Bar Weldment
2	103-33081	1	6' Tine Bar Weldment
3	412-7770	2	Hitch Pin
4	103-42751	2	A-Frame
8	103-42752	1	A-Frame Brace
9	660-3101	1	Bolt, 10x100 MM
10	665-101	1	Nut
11	660-4961	1	Bolt
12	669-1211	1	Lock nut
13	103-42777	1	Mount Frame Weldment
14	412-06571	30	5' Lock nut
14	412-06571	36	6' Lock nut
15	412-00751	30	5' Flat washer
15	412-00751	36	6' Flat washer
16	412-20401	30	5' Bolt
16	412-20401	36	6' Bolt
17	667-101	1	Spring washer
18	668-101	1	Flat washer
19	406-86005	5	5' Tooth support
19	406-86006	6	6' Tooth support
20	105-7149	2	Spacer
21	121-12050	1	Pin w/hair pin
23	151-12050	1	Lock pin
24	401-7263	1	Slotted nut

LIMITED WARRANTY POLICY & REGISTRATION

Modern, Inc. warrants its products for a period of one year after date of sale by authorized dealer to be free from defects in material and workmanship, and will replace at its factory, any parts that will be returned, with shipping charges prepaid, and when examined by us, will disclose it to be defective. This warranty will not apply to implements or parts that have been subjected to misuse, negligence, accident, or that have been altered or repaired.

1. Parts may not be returned without authorization by ModernAg Products.
2. All products returned under warranty inspection claim must be returned PREPAID to our factory.
3. Our obligation under the above warranty is limited to repair or replacement at our factory of any part or parts which Modern, Inc. decides to be defective.
4. Products or parts that have been examined by Modern, Inc. and determined to be improperly operated, damaged by accident or negligence, field repaired or altered, are not covered by this warranty.
5. Modern, Inc. reserves the right to change our specification and designs at any time.
6. This warranty will not obligate Modern, Inc. to bear any cost of labor for field replacement, testing, or adjustment.

DEALER: I hereby certify that:

1. The machine has been correctly assembled in accordance with manufacturers instructions.
2. All bolts have been checked and tightened.
3. All other pre-delivery checks have been completed as per operators manual.
4. Purchaser was given operators manual and instructed in safe and correct usage of machine and on limitation of warranty.
5. Machine was tested and operates correctly.

PURCHASER: I hereby certify that:

1. The machine is correctly assembled.
2. Receipt of the operators manual which I have read and clearly understood.
3. I have a clear understanding of the warranty limitations.
4. I have a clear understanding on the correct and safe operation of the machine
5. That the machine needs regular maintenance as per instructions in operators manual.
6. I have a clear understanding on the capacity of this machine and am aware of its limitations.

MODEL _____

SERIAL # _____

DEALER _____

DATE DELIVERED _____

DEALER'S STAMP

MAIL TO:

PURCHASERS ADDRESS: